



Technical Application Guide for XTLighting LED Downlight

XT.WR110-10W

Introduction



XTLighting SMD LED Down light adopts high lumen SMD LED, PMMA diffuser with even light output. White, silver, chrome surface treatment are available for customer's preference. Triac dimmable, 0-10V dimmable and DALI dimmable version share great popularity by excellent dimming effect.

- Up to 70% energy saving compared to standard CFL
- Long lifetime of 50,000 hours
- Dimmable when using triac dimmer
- 90° wide beam angle
- Ø90-100mm cutout
- CCT: 3000K 4000K
5000K 5700K
- No UV/IR light
- Environment friendly, without Mercury or any other hazardous substances

Application notes

- IP20/IP44 for indoor use
- Professional electrician for installation only
- Switch off before installation
- Do not touch when in use
- Keep away from hot steam and corrosive gas

Application Areas

It is designed for general lighting applications in office, supermarket, shop, school, hotel, etc. It is also widely used for public areas, such as stairway, lobby, reception, corridors etc.

Certificate

CE RoHS SAA



Product Information

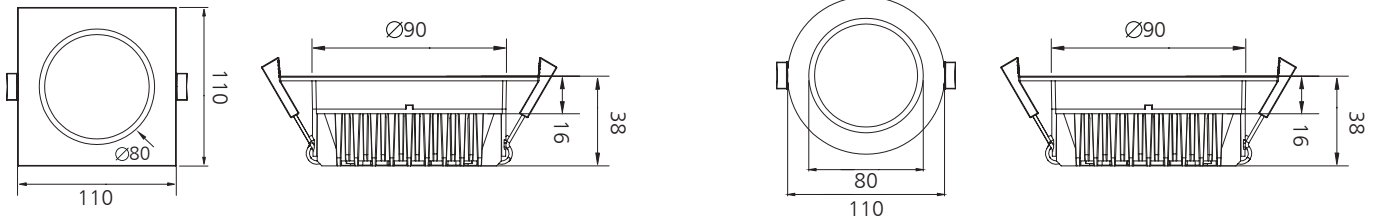

Technical Specifications

Model	Voltage	Power	Power Factor	Lumen (±5%)	CCT	Beam angle	Lifespan	CRI	Dimmable	Dimension
XT.WR110-10W XT.WR110-10WF	AC100-240V	10W	≥0.9	685	3000K	90°	50,000h	≥80	No	Ø110*38mm cutout 90-100mm 110*110*38mm cutout 90-100mm
				700	4000K					
				720	5000K					
				720	5700K					
XT.WR110-10W-D XT.WR110-10WF-D	AC230V	10W	≥0.9	640	3000K	90°	50,000h	≥80	Yes	Ø110*38mm cutout 90-100mm 110*110*38mm cutout 90-100mm
				660	4000K					
				700	5000K					
				700	5700K					

Driver data Sheet

Driver data	DIM	Non-dim
Input rated Voltage	AC230V	AC100-240V
Frequency	50HZ	50/60HZ
Input Voltage	AC200-240V	AC100-240V
Efficiency	≥75%	≥85%
Total load Wattage	10W±1W	10W±1W
Power Factor	≥0.9	≥0.9
Rated input current	≤0.06A	≤0.12A
Full load output Voltage	DC30-33V	DC30-33V
Rated output current	240mA	260mA
Output current range	240mA±5%	260mA±5%
Power tolerance	±5%	±5%
Current output tolerance	±5%	±5%
Dimming range	10%-100%	—
Dimmer	Triac dimmers	—
Withstand voltage	AC3750V	AC3750V
Short circuit protection	PASS	PASS
Over voltage protection	PASS	PASS
Over temperature protection	PASS	PASS

Fixture Compatibility

Rated Wattage	Electrical Classification	Ingress Protection	Operating Temp	Operating Humidity	Storage Temp
10W	II	IP20 / IP44	-20°C~45°C	0~90%	-20°C~65°C

Spectral Distribution

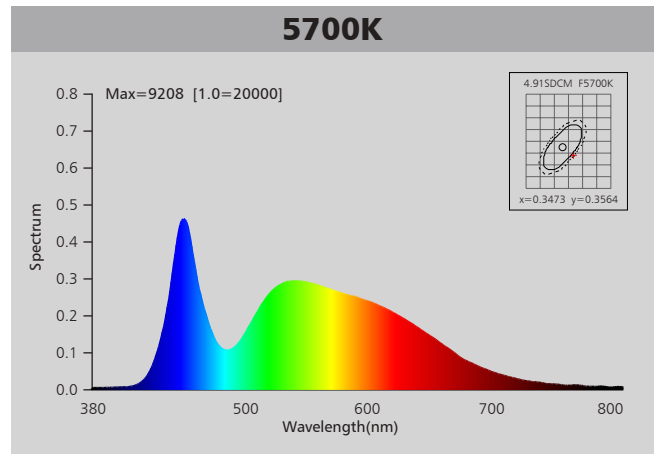
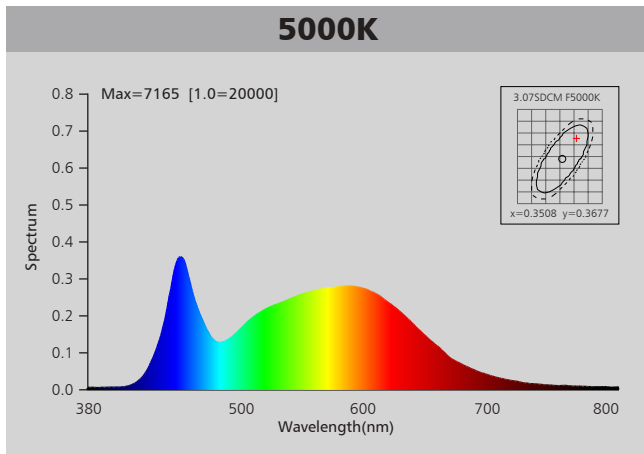
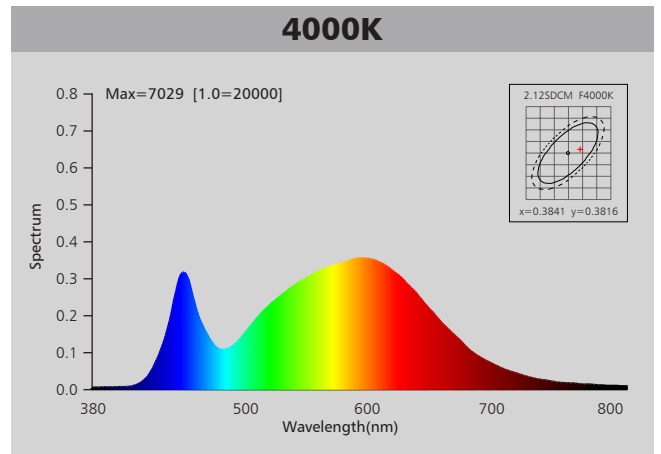
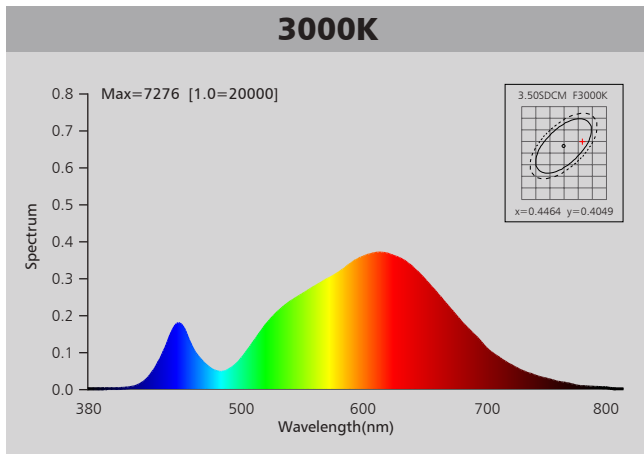

Photometric Diagram

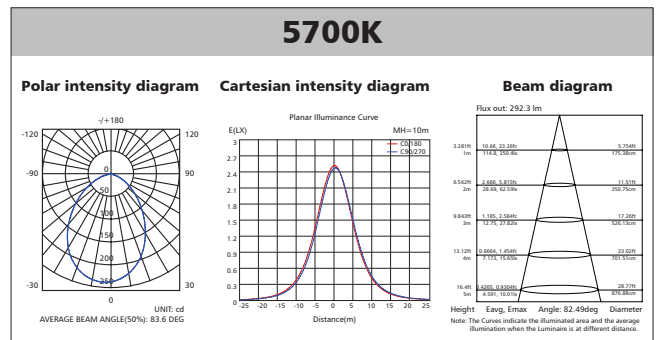
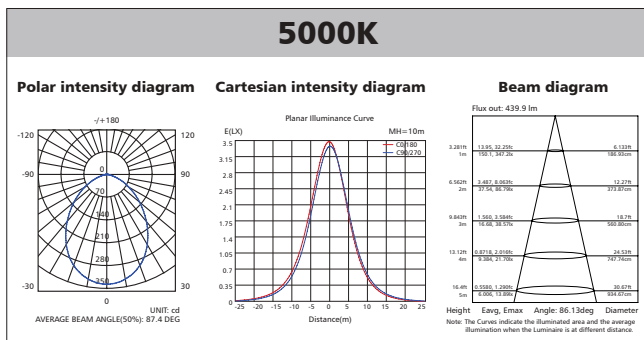
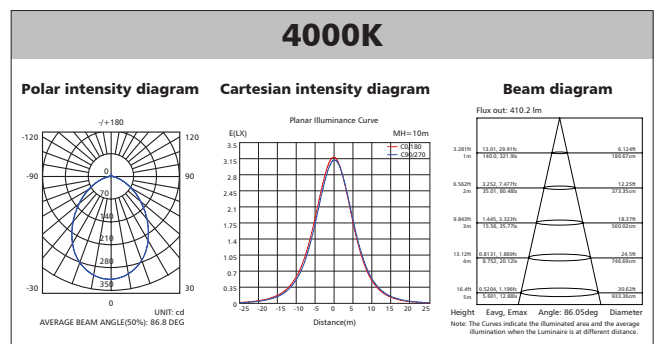
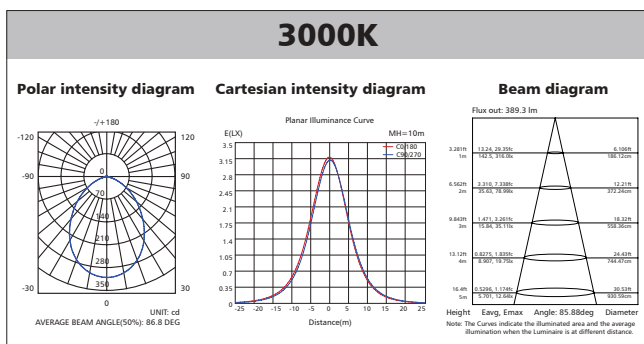

Polar Diagram Comparison

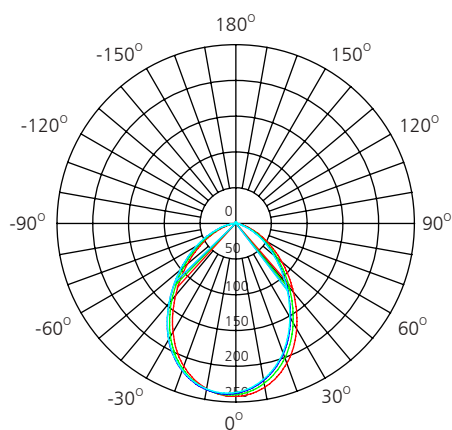

UNIT: cd

- C0/180, 83.3 deg
- C30/210, 83.3 deg
- C60/240, 83.3 deg
- C90/270, 83.3 deg

AVERAGE BEAM ANGLE (50%): 83.3DEG



Driver lifetime & LED light decay rate

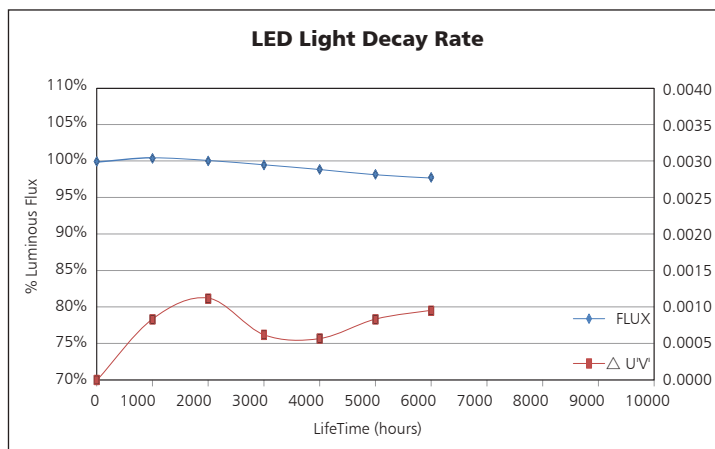
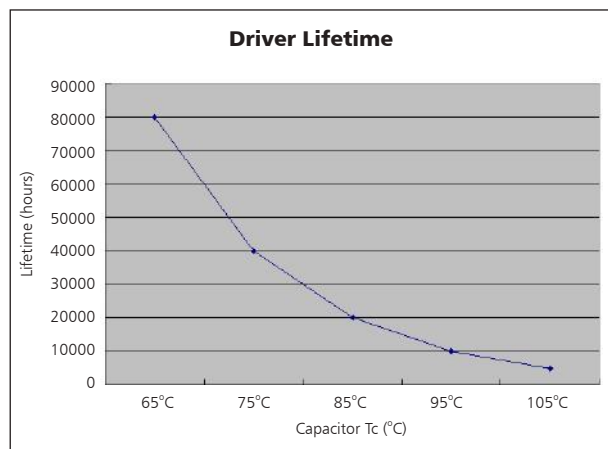

Temperature

- The testing is operated at 25°C
- The lifetime of capacitor, minimum of 5,000 hours if operated at 105°C, will be doubled whenever the temperature drops 10°C
- The highest withstand temperature of IC, MOS could be 120°C
- The highest withstand temperature of LED junction temperature is 150°C

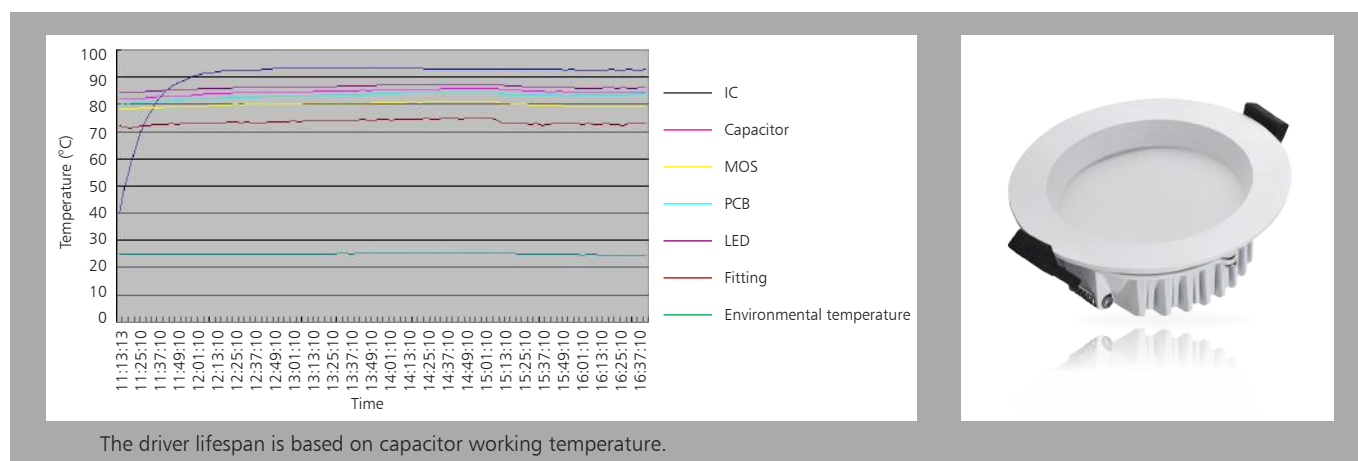

The driver lifespan is based on capacitor working temperature.

Installation

Install requirements	
A-gap above the fitting	25mm
B-gap to the building material	25mm
C-gap to the thermal insulation	25mm

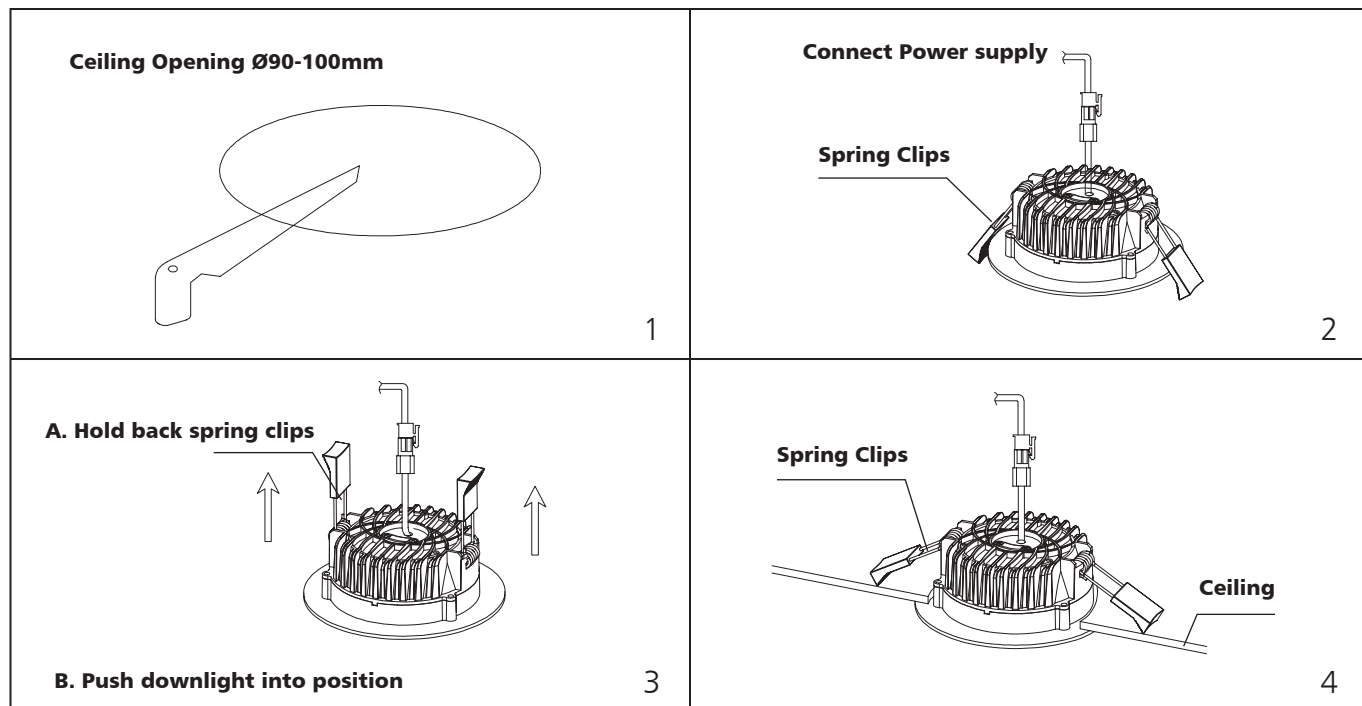
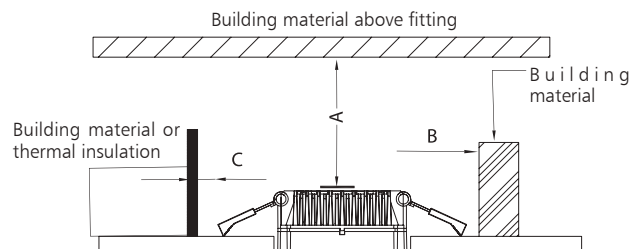

Packaging Information

	SIZE(CM)	N.W/pc (KGS)	G.W.(KGS)	Q'TY(PCS)
Carton	37*48.5*20	0.28	8.7	24

	CTNS	Q'TY(PCS)	VOLUME(CBM)
20" standard container	755	18120	28
40" standard container	1510	36240	56

